

Ch10: Sinusoidal Steady-State Analysis

Nodal Analysis

Overview

This chapter applies the circuit analysis introduced in the DC circuit analysis for AC circuit analysis. We'll see how nodal analysis, mesh analysis, Thevenin's theorem, Norton's theorem, superposition, and source transformations are applied in analyzing AC circuits.

Analyzing ac circuits usually requires three steps:

- 1) Transform the circuit to the phasor or frequency domain.
- 2) Solve the problem using circuit techniques (nodal analysis, mesh analysis, superposition, etc.).
- 3) Transform the resulting phasor to the time domain.

Example

Find i_x in the circuit using nodal analysis.

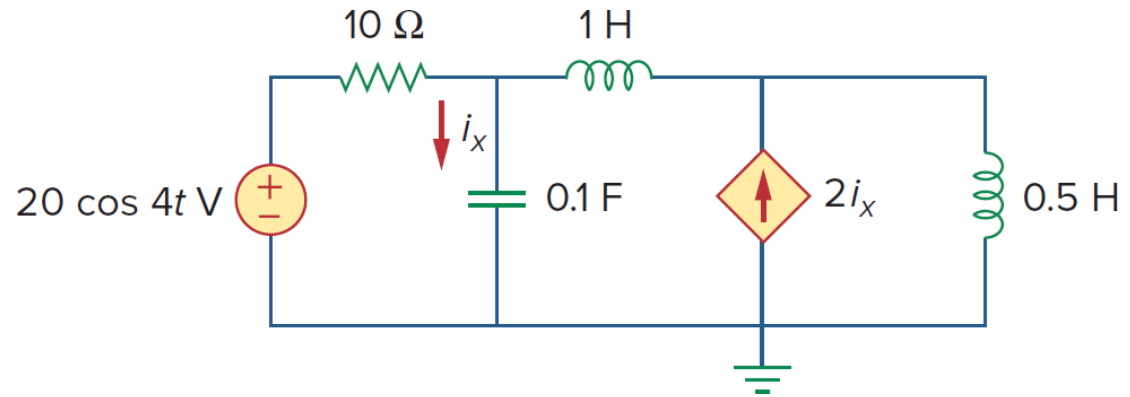

Mesh Analysis

Example

Determine current \mathbf{I}_o in the circuit using mesh analysis.

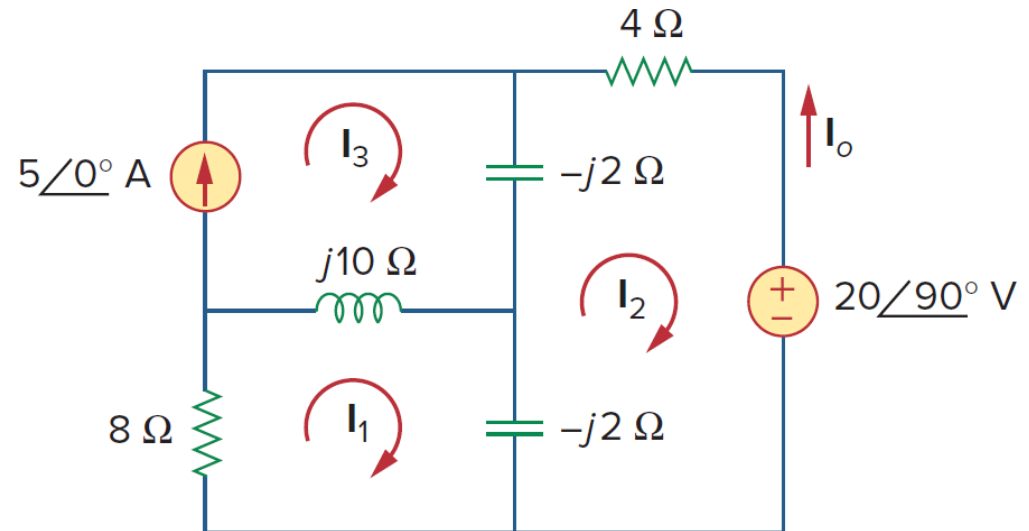

Superposition Theorem

Example

Use the superposition theorem to find \mathbf{I}_o in the circuit.

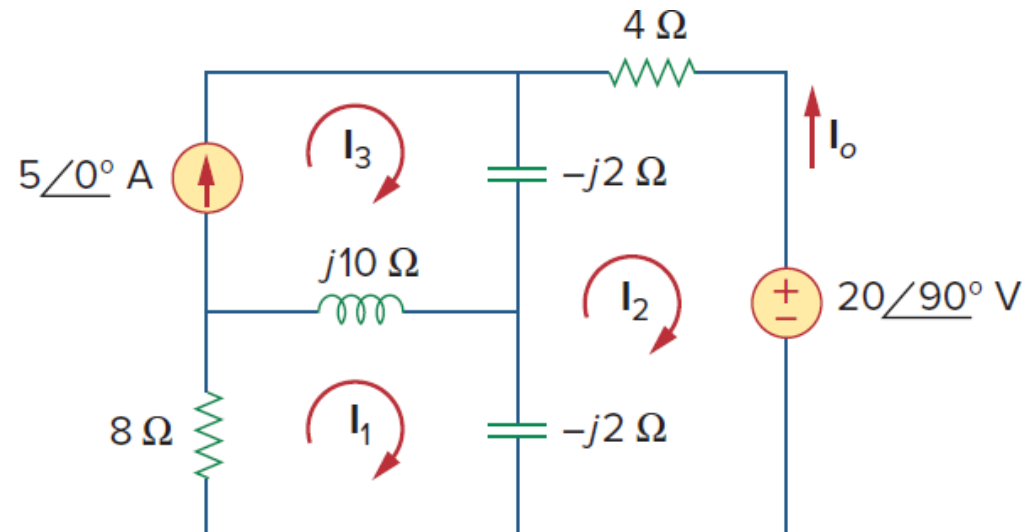

Source Transformation

Source Transformation

Source transformation in the frequency domain involves transforming a voltage source in series with an impedance to a current source in parallel with an impedance, or vice versa.

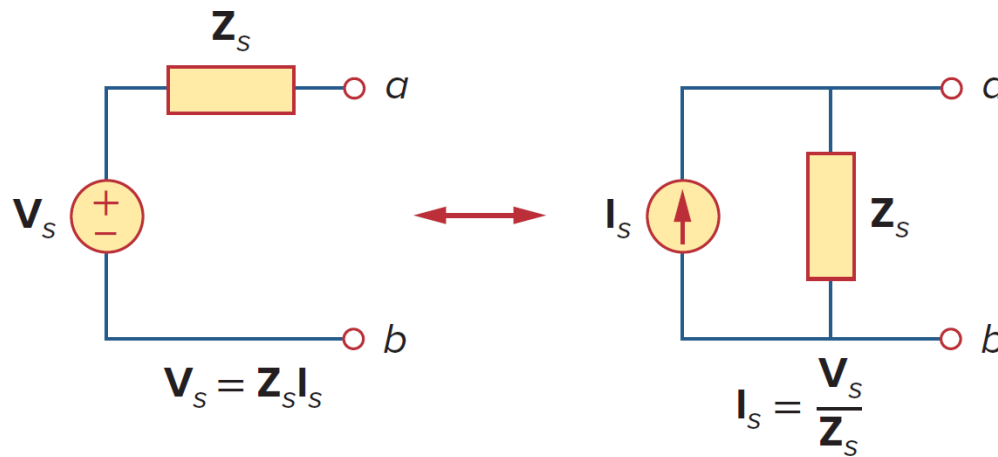

$$V_s = Z_s I_s \Leftrightarrow I_s = \frac{V_s}{Z_s}$$

Example

Calculate \mathbf{V}_x in the circuit using the method of source transformation.

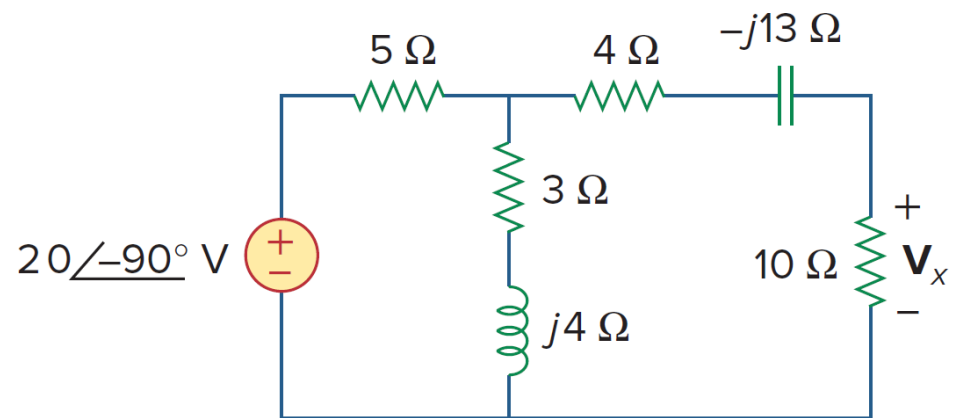

Thevenin and Norton Equivalent Circuits Theorem

Thevenin and Norton Equivalency

Thevenin's and Norton's theorems are applied to AC circuits in the same way as they are to DC circuits. The only additional effort arises from the need to manipulate complex numbers.

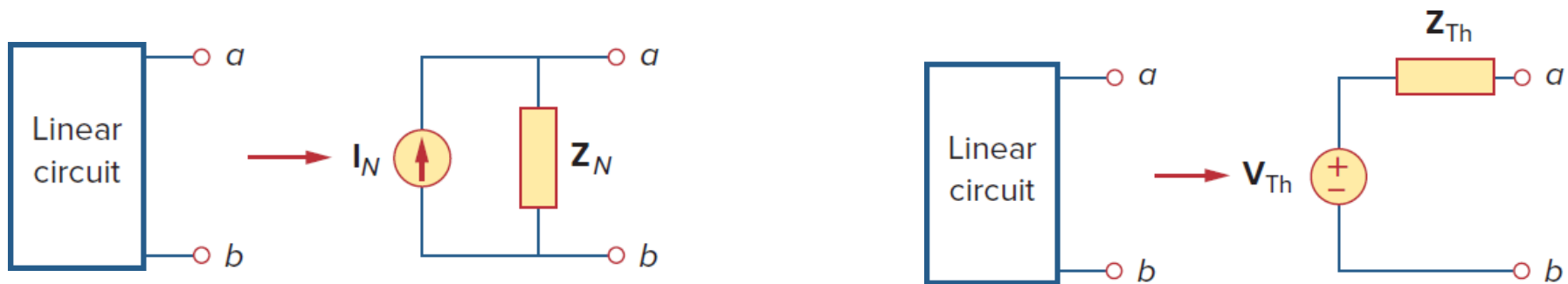

$$V_{Th} = Z_N I_N, \quad Z_{Th} = Z_N$$

V_{Th} is the open-circuit voltage while I_N is the short-circuit current.

Example

Obtain the Thevenin equivalent at terminals $a-b$ of the circuit.

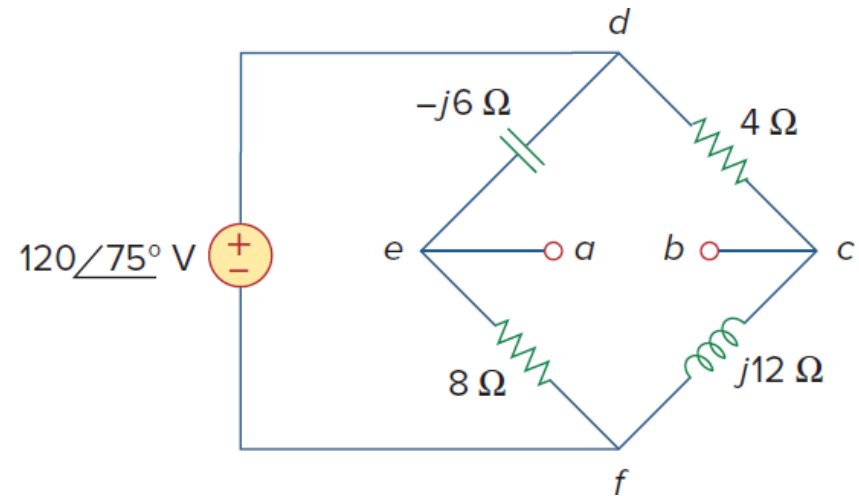

Example

Obtain Thevenin and Norton equivalent circuits at terminals a - b .

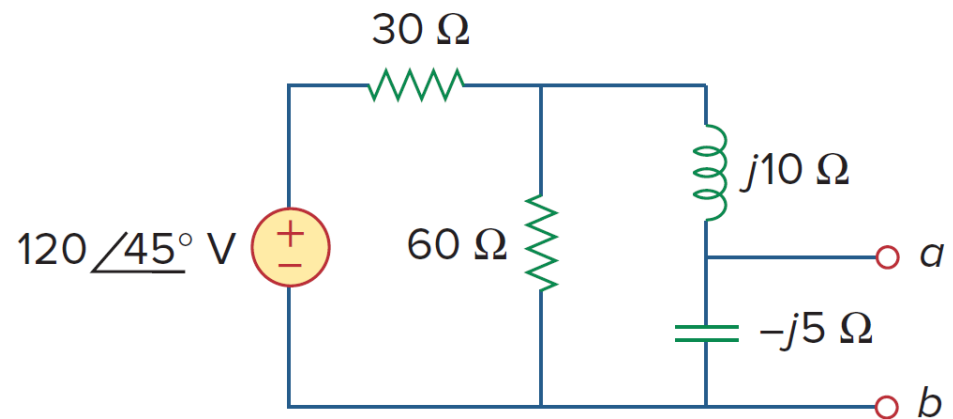

Op Amp AC Circuits

Op Amp AC Circuits

As long as the op amp is working in the linear range, frequency domain analysis can proceed just as it does for other circuits.

It is important to keep in mind the two qualities of an ideal op amp:

- No current enters either input terminals.
- The voltage across its input terminals is zero with negative feedback.

Example

Determine $v_o(t)$ for the op amp circuit if $v_s = 3\cos 1000t$ V.

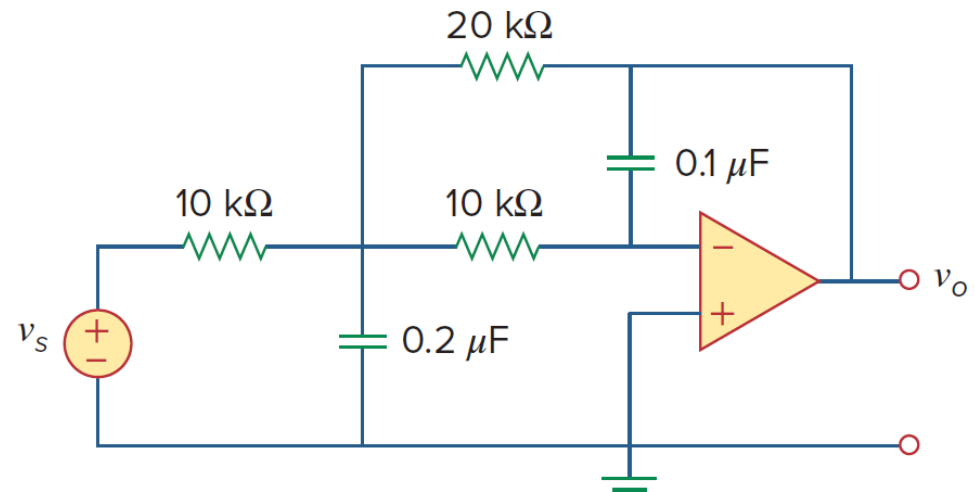

Example

Compute the gain and phase shift between v_s and v_o for the circuit. Assume that $R_1 = R_2 = 10 \text{ k}\Omega$, $C_1 = 2 \text{ }\mu\text{F}$, $C_2 = 1 \text{ }\mu\text{F}$, and $\omega = 200 \text{ rad/s}$.

