

Ch4: Circuit Theorems

Linearity Property

Linearity Property

A major disadvantage of analyzing circuits using Kirchhoff's laws is that, for large, complex circuits, tedious computation is involved. To handle the circuits, some theorems like Thevenin and Norton are used to simplify analysis of **linear** circuits.

The Linearity Property is a combination of both the **homogeneity (scaling) property** and the **additivity property**.

- **Homogeneity Property:** if the input (also called the excitation) is multiplied by a constant, then the output (also called the response) is multiplied by the same constant.

$$v = iR \quad \rightarrow \quad kv = kiR$$

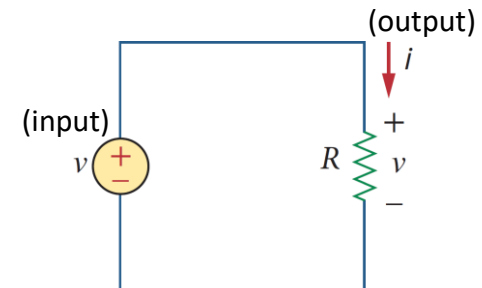

- **Additivity Property:** The response to a sum of inputs is the sum of the responses to each input applied separately.

$$\begin{aligned} v_1 &= i_1 R \\ v_2 &= i_2 R \end{aligned} \quad \rightarrow \quad v_1 + v_2 = (i_1 + i_2) R$$

Linearity Property

A **linear circuit** consists of only linear elements (like resistors), linear dependent sources, and independent sources.

Example:

Consider the linear circuit shown. The linear circuit has no independent sources inside it. It is excited by a voltage source v_s , which serves as the input. The circuit is terminated by a load R . We may take the current i through R as the output. Suppose $v_s = 10$ V gives $i = 2$ A.

According to the linearity principle, $v_s = 1$ V will give $i = 0.2$ A. By the same token, $i = 1$ mA must be due to $v_s = 5$ mV.

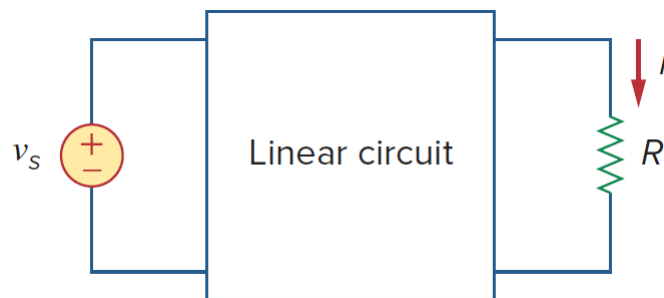

Example

For the circuit, find I_o when $v_s = 12$ V and $v_s = 24$ V.
Use mesh analysis.

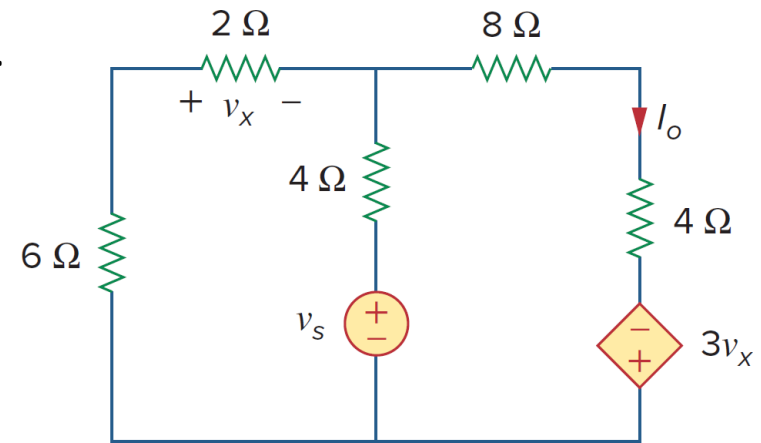

Superposition

Superposition

If a circuit has two or more independent sources (voltage or current), there are two ways to determine the value of a specific variable (voltage or current):

- Using **Nodal Analysis** or **Mesh Analysis**.
- **Superposition Principle** by determining the contribution of each independent source to the variable and then add them up. This idea rests on the linearity property.

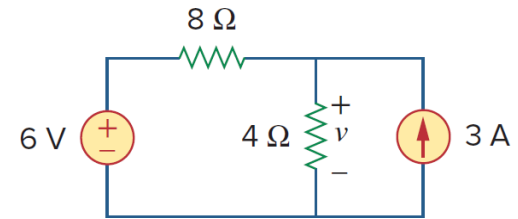

Steps to Apply Superposition Principle:

1. Turn off all independent sources (voltage or current) except one source. For turning off, replace every voltage source by 0 V (or a short circuit) and every current source by 0 A (or an open circuit). This way we obtain a simpler and more manageable circuit. Dependent sources are left intact.
2. Find the output (voltage or current) due to that active source using nodal or mesh analysis.
3. Repeat step 1 for each of the other independent sources.
4. Find the total contribution by adding algebraically all the contributions due to the independent sources.

Example

Use the superposition theorem to find v in the circuit.

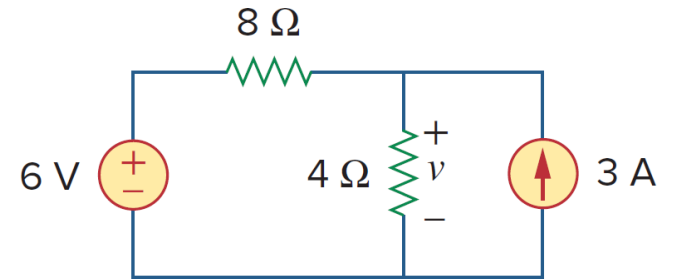

Example

For the circuit, use the superposition principle to find i .

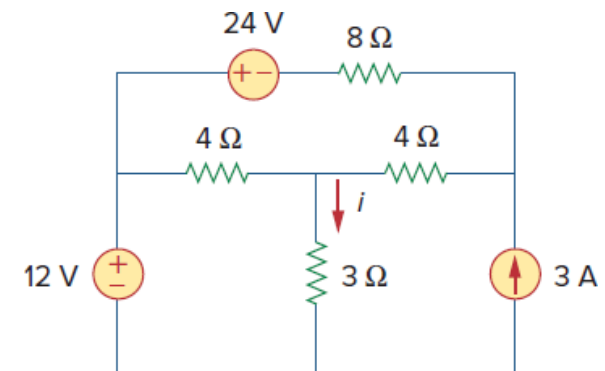

Source Transformation

Source Transformation

A **Source Transformation** is the process of replacing a voltage source v_s in series with a resistor R by a current source i_s in parallel with the same resistor R , or vice versa.

Note: Arrow of the current source is directed toward the positive terminal of the voltage source.

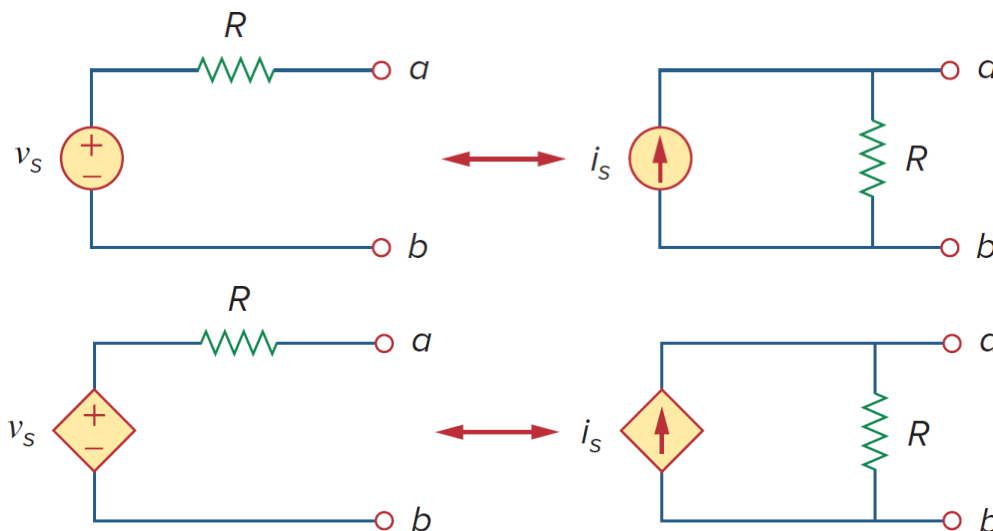

$$v_s = i_s R$$

- Source transformation is a tool for simplifying circuits.
- Basic to these tools is the concept of equivalence of circuits, i.e., they have the same voltage-current relation at terminals a - b .
- A source transformation does not affect the remaining part of the circuit.

Example

Use source transformation to find v_o in the circuit.

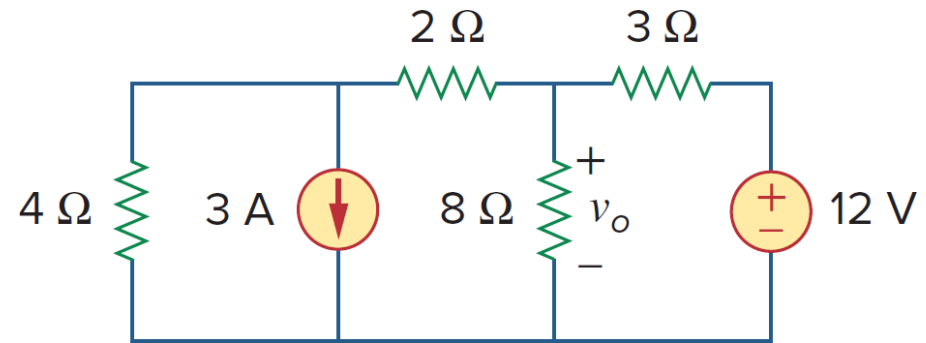

Example

Find v_x using source transformation.

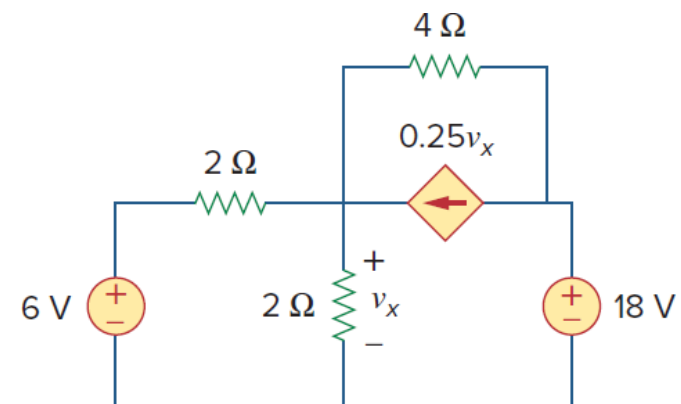

Thevenin's Theorem

Thevenin's Theorem

- It often occurs in practice that a particular element in a circuit is variable (usually called the **load**) while other elements are fixed. For example, many different appliances may be plugged into the outlet, each presenting a different resistance.
- Each time the variable element is changed, the entire circuit has to be analyzed all over again.
- To avoid this problem, Thevenin's theorem provides a technique by which the fixed part of the circuit is replaced by an equivalent circuit consisting of a voltage source V_{Th} in series with a resistor R_{Th} .

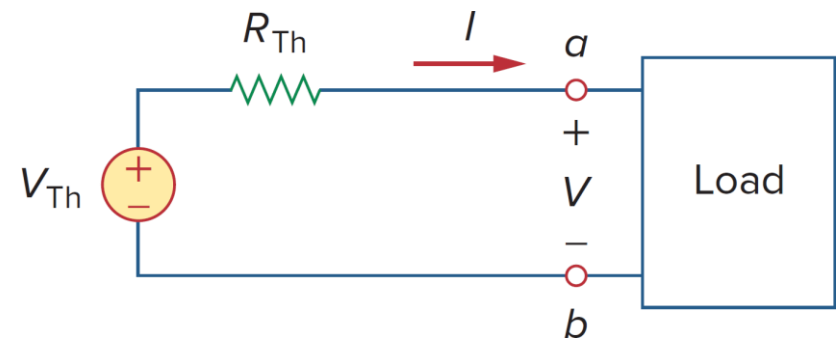
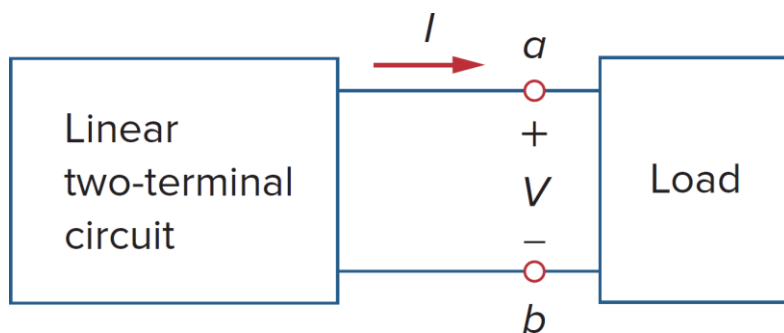

Thevenin's Theorem

- R_{Th} is the equivalent resistance at the terminals when the terminals $a-b$ are made **open-circuited** (by removing the load), and all the **independent sources are turned off** (by replacing the voltage source with short circuit and current source with open circuit).
- V_{Th} is the open-circuit voltage at the terminals. If the terminals $a-b$ are made **open-circuited** (by removing the load), no current flows, so that the open-circuit voltage across the terminals $a-b$ must be equal to V_{Th} .

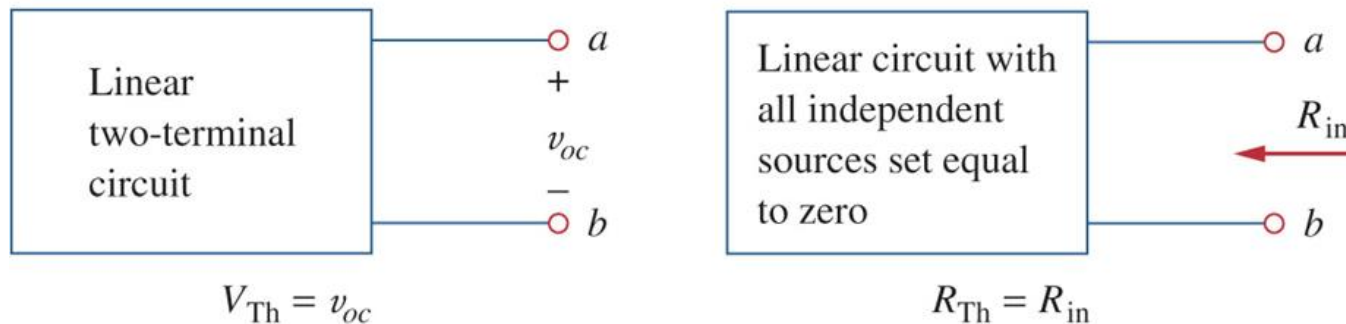

- ❖ Thevenin's theorem is a powerful tool in circuit design and this replacement technique helps simplify a circuit.

Example

Find the Thevenin equivalent circuit of the circuit shown, to the left of the terminals a-b. Then find the current through $R_L = 6, 16,$ and 36Ω .

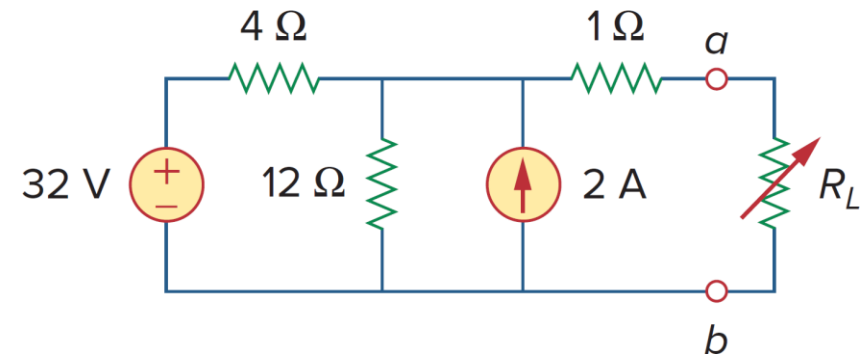

Norton's Theorem

Norton's Theorem

Similar to Thevenin's theorem, Norton's theorem states that a linear two-terminal circuit can be replaced by an equivalent circuit consisting of a current source I_N in parallel with a resistor R_N .

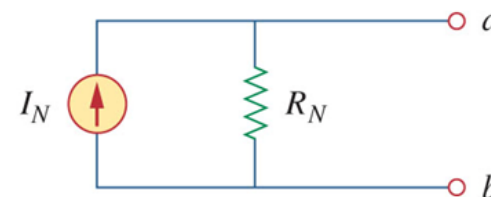
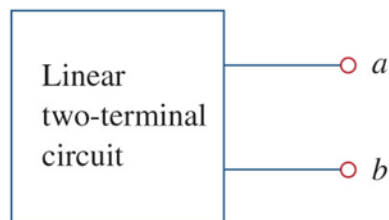

- R_N is found in the same way we find R_{Th} . That is, R_N is the equivalent resistance at the terminals when the terminals $a-b$ are made **open-circuited** (by removing the load), and all the **independent sources are turned off** (by replacing the voltage source with short circuit and current source with open circuit).
- I_N is the short-circuit current through terminal $a-b$. It is found by **short circuiting** the circuit's terminals and measuring the resulting current.

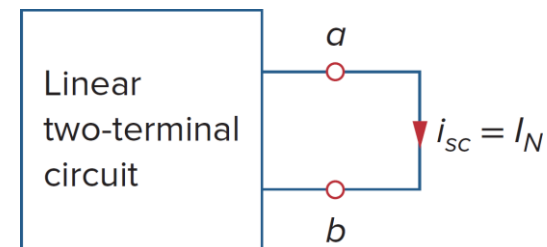

Example

Find the Norton equivalent circuit at terminals a - b .

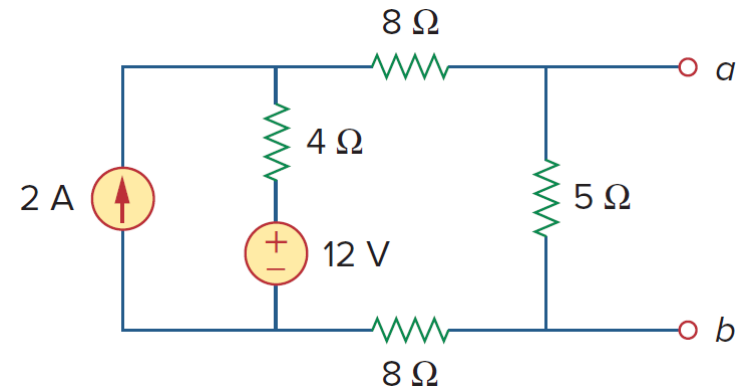

Norton versus Thevenin

Thevenin and Norton equivalent circuits can be related to each other.

$$R_N = R_{Th}$$

$$I_N = \frac{V_{Th}}{R_{Th}}$$

This is essentially source transformation.

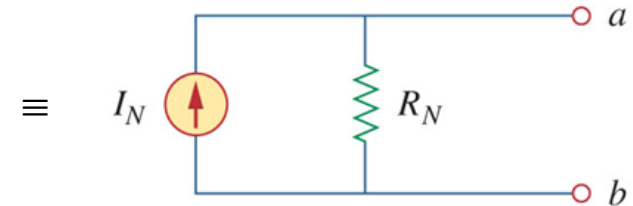
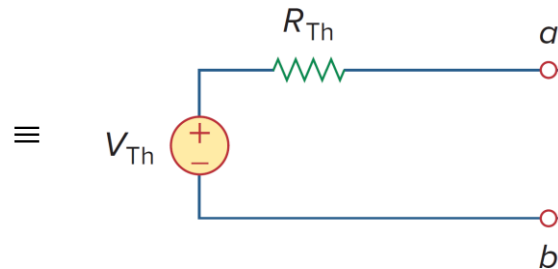
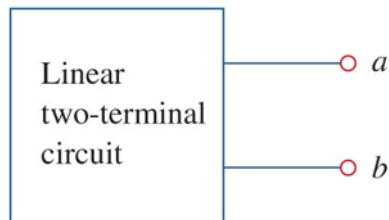

We can calculate any two of the three using the method that takes the least effort and use them to get the third using Ohm's law.

Example

Find the Thevenin and Norton equivalents at terminals a - b of the circuit.

Hint: For finding V_{TH} first use source transformation for 1-A source and 6- Ω resistor.

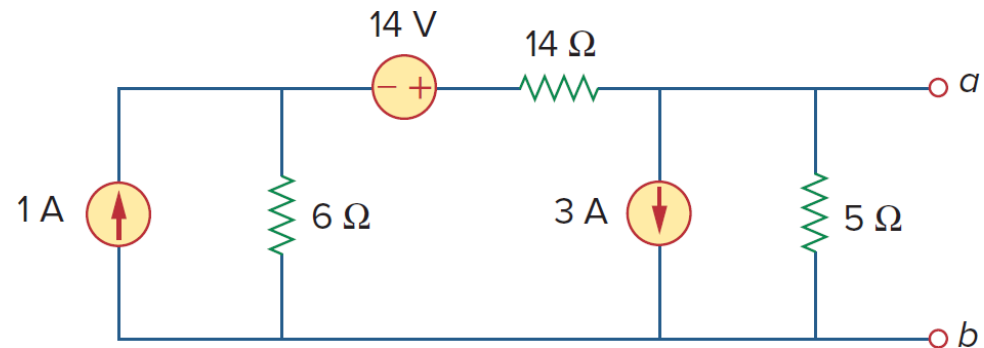

Maximum Power Transfer

Maximum Power Transfer

In many applications, a circuit is designed to power a load R_L . Among those applications, there are many cases where we wish to maximize the power transferred to the load.

- The Thevenin equivalent is useful in finding the maximum power a linear circuit can deliver to a load.
- Maximum power is transferred to the load when the load resistance equals the Thevenin resistance as seen from the load.

$$R_L = R_{Th}$$

The maximum power transferred is obtained by

$$p_{\max} = \frac{(V_{Th}/2)^2}{R_{Th}} = \frac{V_{Th}^2}{4R_{Th}}$$

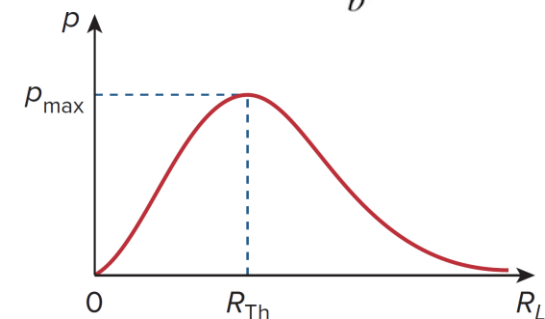
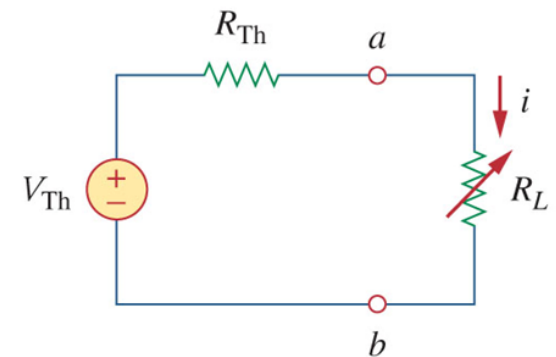

(For a given circuit, V_{Th} and R_{Th} are fixed. By varying the load resistance R_L , the power delivered to the load varies.)

Example

Find the value of R_L for maximum power transfer in the circuit. Find the maximum power.

